

A Healthcare/Eldercare Robot based on Skilligent Technology

Application Proposal

Revision 7

TABLE OF CONTENTS

1	<u>INTRODUCTION</u>	3
2	<u>CONCEPTION OF AN ELDERCARE/HEALTHCARE ROBOT</u>	4
3	<u>FUNCTIONS OF THE HEALTHCARE/ELDERCARE ROBOT</u>	5
4	<u>HOW THE ROBOT MONITORS THE PATIENT'S HEALTH</u>	6
5	<u>BODY TEMPERATURE SCREENING</u>	7
6	<u>AUXILIARY FUNCTIONS</u>	7
7	<u>LEARNING CAPABILITIES OF THE ROBOT</u>	7
8	<u>ABOUT SKILLIGENT</u>	8

1 Introduction

This document studies a potential application of the Skilligent Robot Learning and Behavior Control System in the healthcare and eldercare domains.

The document provides a conceptual description of an autonomous healthcare/eldercare robot which is based on the capabilities of the Skilligent control software.

The target readers of the document are robotics solution providers, healthcare/eldercare establishments and assisted living facilities.

Skilligent Robot Learning and Behavior Control System is a complete control system for autonomous service robots, including a behavior control and coordination system, task and skill learning functions, a powerful computer vision system, a social human-to-machine interface, a database for storing knowledge and other integrated components.

2 Conception of an Eldercare/Healthcare Robot

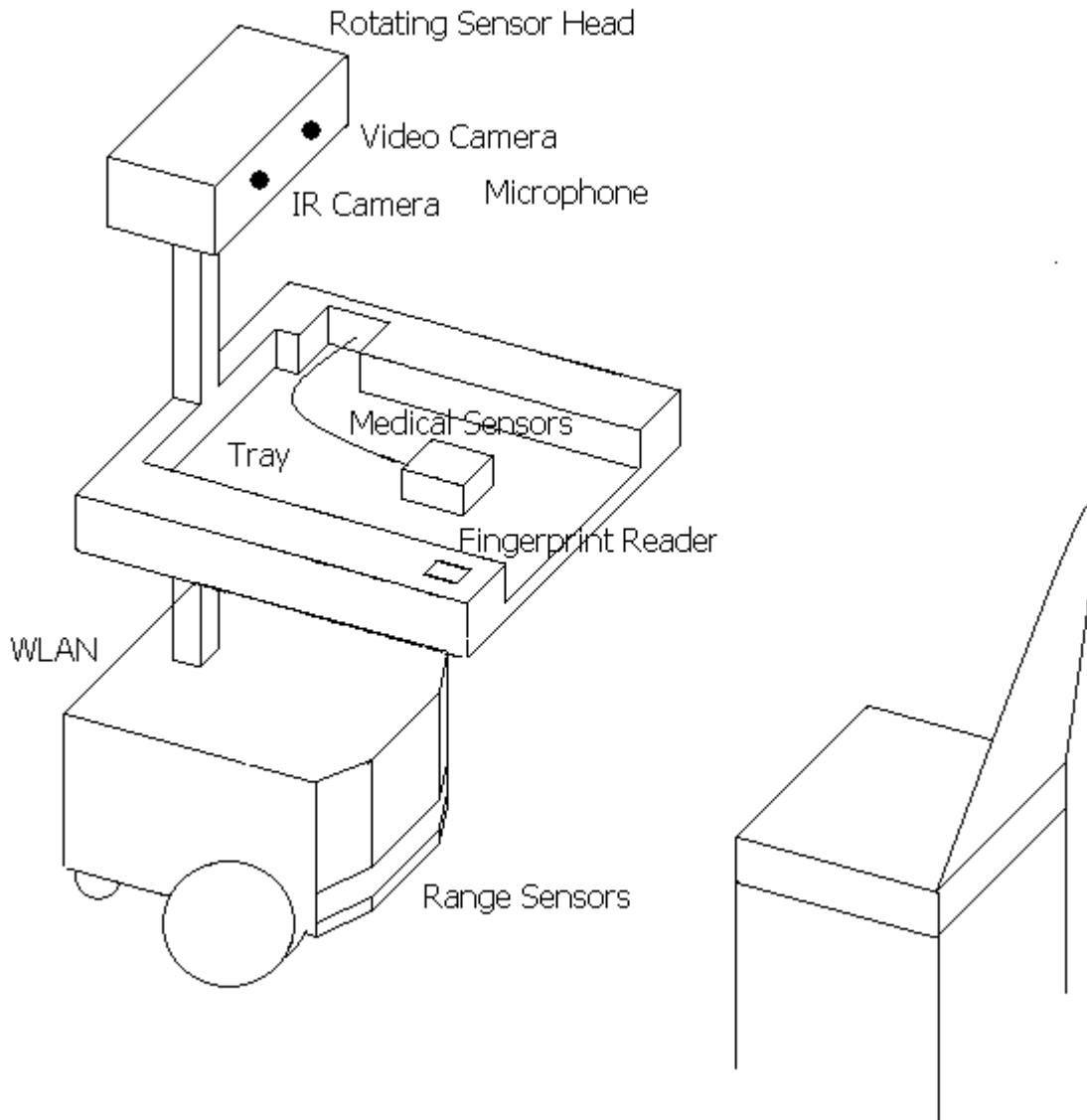

Figure 1 Conception of an Eldercare/Healthcare Robot

The robot is designed to operate on the floors of assisted living facilities, eldercare facilities, healthcare facilities, hospitals or at homes. The robot is capable of automatically scanning the patients' health and assisting the patients and the care givers in their daily routines.

3 Functions of the Healthcare/Eldercare Robot

The Skilligent Robot Learning and Behavior Control System enables the robot to do the following:

1. Autonomously Navigate through an assisted living facility, a hospital, an eldercare facility or a home.
2. Monitor Health Monitoring of Patients on a regular basis
 - a. Take Blood Pressure,
 - b. Measure Body Temperature,
 - c. Heartbeat Rate,
 - d. Heartbeat Irregularities,
 - e. Pulse oximetry.
3. Submit the medical data into a centralized medical IT system over wireless network (WLAN).
4. Detect people lying on the floor, call for help.
5. Remind about the need to take the medication.
6. Communicate to elders from time to time; check that everything is ok; call for help in case of a trouble.
7. Provide remote video and audio connection for the care-givers and doctors (telepresence).
8. Deliver meals, collect dishes, deliver plates to a dishwasher location.
9. Transport objects to certain locations.
10. Guide the elders around the place, escort guests, providing guidance.
11. Recognize patients by voice, face or name.
12. Act as a security robot in the night, detect intrusions, call for help.
13. Detect fire and smoke, call for help.
14. Entertain the patients (e.g. joke of the day).

4 How the robot monitors the patient's health

1. The robot is equipped with a set of medical sensors.
2. The robot approaches a patient and suggests doing a regular health check up (according to a schedule).
3. The patient turns attention to the robot and responds. The robot recognizes the patient by taking the finger prints, by analyzing the voice, or by recognizing the face. If the patient is not recognized, the robot may ask for her name¹.
4. The patient sits down on a chair/bed; the robot drives closer to the patient.
5. The patient extracts the medical sensor pack from the robot's tray. The patient puts the sensors on its hand and fingers.
6. The robot measures the blood pressure, heartbeat rate, heartbeat irregularities, body temperature, performs pulse oximetry measurements.
7. If the robot has identified who the patient is:
 - The robot may submit the taken medical readings to a centralized medical IT system.
 - Remind the person about the medication which needs to be taken.
 - Send a notification (e.g. an email) to the patient's care-givers about the health status.
 - Alert the patient if the medical readings are out of norm.
8. After the regular health check-up has been made, the robot may ask if the patient needs any help or assistance such as:
 - Talk to care-givers
 - Deliver something to somewhere (e.g. the patient may put plates on the robot's tray and ask the robot to transport those to the kitchen)

¹ Additional electronic means of the identification include visual tags on the clothes, RFID tags, electronic keys, and PIN codes.

5 Body Temperature Screening

The robot can be optionally equipped with an infrared thermometer for remote body temperature screening. When the robot moves around the place and meets people, it may detect if a person has a fever without touching the person.



Figure 2 - An image from a commercial fever detection camera

6 Auxiliary Functions

The robot can be equipped with various additional sensors such as smoke detectors, motion detectors, temperature sensor, humidity sensor and gas sensor.

Those sensors enable the robot to perform fire detection, security, and environmental monitoring functions.

7 Learning Capabilities of the Robot

As nearly every care facility is different, the learning capabilities of the Skilligent Robot Learning and Behavior Control System allow the robot to be trained to operate in the particular environment:

- Learn the daily procedure of regular health check up.
- Learn how to handle the typical patient's requests.
- Learn how to visit rooms on a particular floor.
- Learn a daily entertainment procedure.

In the past, the robots had to be programmed or configured by IT professionals to perform those kinds of procedures. With the introduction of the robot learning technology, a non-professional employee (e.g. a floor manager) can adopt the robots' behavior to particular needs of the particular care facility.

The robots can learn totally new behaviors when their users decide the robots need to handle more work. For example, those robots can be trained to push or pull wheeled chairs, clean floors, deliver the medication, or assist in medical procedures.

8 About Skilligent

Skilligent's flagship product is a trainable control system for autonomous robots such as mobile service robots, UGV, UAV or AUV. The software enables the robots to learn new behaviors, tasks and skills by observing how human operators accomplish the same tasks. A robot vision system, a part of the package, reliably recognizes objects, landmarks and gestures under real life conditions. The vision system enables the robots to visually navigate, control a manipulator and socially interact with the users.

<http://www.skilligent.com>